

Instruction Manual

CVS Type 630 HP Regulators and Relief Valves

Introduction

Please note: These regulators and relief valves must be installed, operated and maintained in accordance with CVS instructions and all applicable federal, provincial, state and local codes, laws, rules, and regulations.

The CVS 630 HP Series consists of a high pressure reducing regulator, and Type CVS 630R relief valve. These regulators and relief valves are furnished in either spring-loaded or pressure-loaded construction with 1 or 2 inch NPT screwed end connections and ASME Class 150 through 600 RF Flanged end connections.

Pressure loaded Type 630 HP regulators are normally furnished without a main regulator spring and use a Bellofram 7360 or a Bellofram P39 regulator.

Pressure loaded Type 630R relief valves are furnished with a light rate relief valve spring and use a Bellofram 7360 or a Bellofram P39 regulator.

Installation

After uncrating the regulator or relief valve, inspect it for shipping damage. Be certain the body cavity and seat ring are free from any foreign material. Also be certain that connecting pipelines are free of loose pipe scale.

The regulator or relief valve may be installed in any position, but direction of flow through the body must

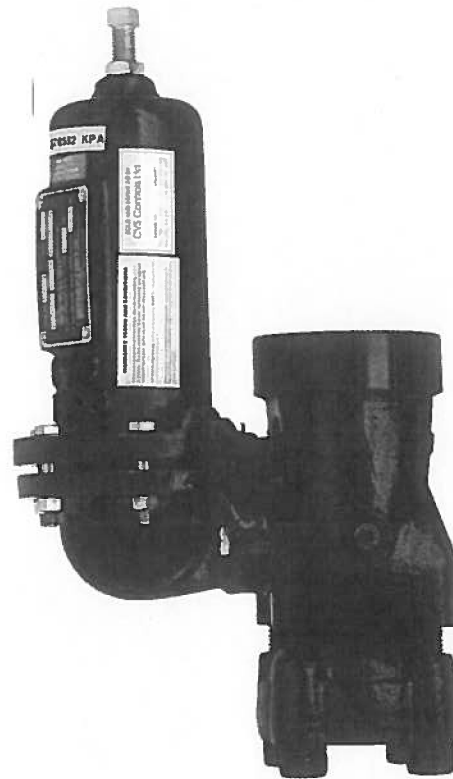

be as indicated by the flow direction arrow on nameplate.

Note that in diagrams in this manual, regulator flow direction is opposite relief valve flow direction.

Protect the regulator or relief valve against damage from vehicles and other external sources. The temperature capability of the 630 HP Series regulator and relief valves with standard construction materials is -20 to +150°F, optional construction -20 to 300°F.

Vents

Spring-loaded constructions have a screened vent assembly (Key 24) installed in the 1/4" NPT spring case vent opening. If a remote vent is required, remove the vent assembly and install a remote vent line.

Pressure loaded constructions have a bleed orifice fitting (Key 38) installed in an extra outlet connection of the loading regulator. The function of this fitting is to bleed loading pressure during operation of the regulator or relief valve.

Warning: The bleed orifice fitting continuously vents a small amount of gas. If the regulator or relief valve is located where accumulation of the vented gas will create an explosion hazard, install a remote vent line to carry the vented gas to a safe area. The bleed orifice is furnished with a 1/4" NPT screened opening; remove the screen and install remote vent line.

All remote vent lines must have as large an inside diameter as possible. The vent line should be as short as possible with a minimum number of bends and elbows. Protect all vent openings against entrance of rain, snow or any other foreign material that may plug the vent or affect operation of the regulator or relief valve. Inspect all vent openings periodically to be sure they are not plugged.

Overpressure Protection

As is the case with most regulators, the Type 630 HP spring-loaded and pressure-loaded regulators have outlet pressure ratings that are lower than the inlet pressure ratings. Overpressure protection must be provided if the actual inlet pressure can exceed the outlet pressure rating. Overpressure protection may also be required for the loading regulator and main regulator spring case of pressure loaded regulators and relief valves.

Refer to the following tables to determine pressure ratings:

1. Spring loaded Type 630 HP regulators
 - 1.1. Inlet pressure and pressure drop (Table 1)
 - 1.2. Outlet pressure (Table 2)
2. Pressure loaded Type 630 HP regulators
 - 2.1. Main regulator inlet pressure and pressure drop (Table 1)
 - 2.2. Loading pressure and outlet pressure (Table 3)
3. Spring loaded Type 630R relief valve pressure (Table 4)
4. Pressure loaded Type 630R relief valve pressures (Table 5)

WARNING: Over pressuring any portion of this equipment may cause damage to regular parts, leaks in the regulator or personal injury due to bursting of pressure-containing parts or explosion of accumulated gas.

To prevent overpressure, provide an appropriate overpressure protection device to ensure that none of the limits listed in tables 1 through 5 will be exceeded.

Regulator or relief valve operation below the limits specified in tables 1 through 5 does not preclude the possibility of damage from external sources or from debris in the gas line. Inspect the regulator for damage following any over pressuring condition.

Loading Regulator Supply Pressure

Use a clean, dry gas as supply pressure for the loading regulator of pressure loaded regulators or relief valves. Connect the supply to the 1/4" NPT inlet connection of the loading regulator. The supply pressure may be obtained from the upstream piping, but be certain adequate overpressure protection is provided for the loading regulator and for the spring case of the main regulator or relief valve.

Table 1: Maximum Inlet Pressures and Pressure Drops for CVS Type 630 HP Regulators

	1/8" & 3/16" Port Diameter	1/4" Port Diameter	3/8" Port Diameter	1/2" Port Diameter
Max. Allowable Inlet Pressure, (PSIG)	1500*	1500*	1000*	750*
Max. Allowable Pressure Drop, ** (PSIG)	1500	1000	500	250

Does not apply to loading regulator of pressure-loaded Type 630 HP.

+ Inlet pressure must not exceed the sum of the actual outlet pressure setting and the maximum allowable pressure drop. For example, with an outlet pressure setting of 200 psig and a 3/8" port dia. (maximum allowable pressure drop of 500 psig), the maximum allowable inlet pressure is 700 psig.

++ Nitrile valve discs are normally furnished for pressure drops to 200 psi. For better erosion resistance, nylon valve discs are normally furnished for higher-pressure drops.

Some erosion of valve discs occurs at all pressure drops due to solid particles in the flow stream. The rate of erosion is higher with large amounts of impurities in the flow stream and with higher pressure drops. Valve discs and other regulator parts must be inspected periodically for erosion and damage and must be replaced as necessary.

Table 2: Outlet Pressure Limits for Spring-Loaded CVS Type 630 HP Regulators

	Low-Pressure Regulator				High-Pressure Regulator					
Outlet Pressure range	3 to 10 psig	8 to 20 psig	17 to 30 psig	27 to 40 psig	27 to 50 psig	46 to 95 psig	90 to 150 psig	150 to 200 psig	200 to 275 psig	275 to 500 psig
Spring Part Number	CVS0W 0192 27022	CVS0W 0191 27022	CVS0W 0190 27022	CVS0Y 0664 000A2	CVS0W 0192 27022	CVS0W 0191 27022	CVS0W 0190 27022	CVS0Y 0664 000A2	CVS1J 1469 27142	CVS1K 3709 27082
Maximum Operating Outlet Pressure, PSIG	10	20	30	40	50	95	150	200	275	500
Max. Outlet Pressure Over Pressure Setting ¹ , PSIG	20		20 ²	Ltd. By Max. emr Outlet Pr.	200					200 ³
Max. Emergency Outlet (Casing) Pressure, PSIG	45				550					
1. Damage to internal parts of the regulator may occur if outlet pressure exceeds the actual pressure setting by amounts greater than shown in this row. 2. For outlet pressure settings to 25 psig only. For pressure settings over 25 psig, outlet pressure is limited by max. emergency outlet pressure of 45 psig. 3. For outlet pressure settings to 350 psig only. For pressure settings over 350 psig, outlet pressure is limited by max. emergency outlet pressure of 550 psig. 4. Leakage or bursting of pressure-containing parts may occur if outlet pressure exceeds these values.										

Table 3: Loading Pressure and Outlet Pressure Limits for Spring-Loaded CVS Type 630 HP Regulators

	Low-Pressure Regulator		High-Pressure Regulator	
Loading Regulator Type	Bellofram 7360	Bellofram P39	Bellofram 7360	Bellofram P39
Max. Inlet Pressure to loading regulator, psig	250	600	250	600
Outlet Pressure Ranges, ² psig	0 to 30 0 to 60	0 to 225	0 to 120	50 to 225 200 to 500
Max. Operating Outlet Pressure, ² psig	60		100	500
Max. Main Regulator Outlet Pressure Overpressure Setting, ³ psig	20 ⁴		200	200 ⁵
Max. Emergency Outlet (Casing) Pressure of Loading Regulator, ⁶ psig	70 ⁷		110	550
Max. Emergency Outlet (Casing) Pressure of Main Regulator, ⁶ psig	70		600	
1. Limited to this value by maximum inlet pressure to Type 630 HP 2. Applies to both loading regulator and main regulator. 3. Damage to internal parts of the regulator may occur if outlet pressure exceeds the actual pressure setting by amounts greater than those shown in this row. Loss of loading pressure to main regulator diaphragm will reduce outlet pressure settings in proportion to the loss in loading pressure. 4. For pressure settings to 46 psig. For higher-pressure settings, outlet pressure is limited by max. emergency outlet pressure of 66 psig. 5. For pressure settings to 350 psig. For higher-pressure settings, outlet pressure is limited by max. emergency outlet pressure of 550 psig. 6. Leakage or bursting of pressure-containing parts may occur if outlet pressure exceeds these values. 7. Limited to this value by maximum emergency loading pressure of main regulator.				

Table 4: Relief Valve Pressure Limits for Spring-Loaded CVS Type 630R Regulators

	Low Pressure Relief Valve					High Pressure Relief Valve			
Max. Allowable Inlet Pressure, psig	Relief Pressure Setting Plus Maximum Allowable Buildup of 25 psig					Relief Pressure Setting Plus Maximum Allowable Buildup of 250 psig			
Max. Emergency Inlet (Casing) Pressure, ¹ psig	75					550			
Relief Pressure Settings (psig)	3 to 8	6 to 17	15 to 22	20 to 35	27 to 50	30 to 70	50 to 95	75 to 175	150 to 250
Spring Part Number	CVS0W 0192 27022	CVS0W 0191 27022	CVS0W 0190 27022	CVS0Y 0664 000A2	CVS1J 1469 27142	CVS0W 0191 27022	CVS0W 0190 27022	CVS0Y 0664 000A2	CVS1J 1469 27142
Leakage or bursting of pressure-contained parts may occur if inlet pressure exceeds these values									

Table 5: Relief Valve Pressure Limits for Pressure-Loaded CVS Type 630R Regulators

Loading Regulator Type	Low Pressure Relief Valve	High Pressure Relief Valve	
	Bellofram 7360	Bellowfram 7360	Bellofram P39
Max. Allowable Inlet Pressure to Relief Valve, PSIG	Relief pressure setting plus maximum Allowable buildup of 25 psig	Relief pressure setting plus maximum Allowable buildup of 250 psig	
Max. Emergency Inlet (Casing) Pressure * of Relief Valve, PSIG	75	550	550
Max. Allowable Inlet Pressure to Loading Regulator, PSIG	75+	250	550+
Relief Pressure Settings, PSIG	10 to 20 or 20 to 50	50 to 100	100 to 225
Max. Emergency Outlet (Casing) Pressure * of Loading Regulator, PSIG	75++	110	250
* Leakage or bursting of pressure-contained parts may occur if pressure exceeds these values + Limited to this value by maximum emergency inlet pressure of relief valve ++ Limited to this value by maximum emergency loading pressure of Type 630R			

Putting Unit in Service

Use pressure gauges to monitor pressure during startup.

1. For pressure loaded constructions, turn on supply pressure to loading regulator.
2. Slowly open upstream shutoff valve.
3. Slowly open the downstream shutoff valve.
4. Check all connections for leaks.
5. If indicated by the monitoring pressure gauges, make final spring adjustments per the "Adjustment" section.

Adjustment

The range of allowable pressure settings is marked on the nameplate. If a pressure setting beyond the nameplate range is required, substitute an appropriate spring in the relief valve or loading regulator. Be sure to change the nameplate to indicate the new pressure range.

Some pressure ratings are dependent upon the actual outlet pressure settings being used. For example, with a Type 630 HP regulator, outlet pressure must not exceed the setting by more than 20 psig (200 psig for high-pressure constructions), or damage to internal regulator parts may occur. However, with some higher-pressure ranges, the setting plus 20 psig (200 psig for high-pressure constructions) exceeds the maximum emergency outlet (casing) pressure. In these cases, outlet pressure must be limited by the maximum emergency outlet (casing) pressure. Before increasing the setting, refer to table 2 through 5 (as appropriate). Review the pressure limits for the spring range being used, and be certain that the new pressure setting will not result in an overpressure condition. Always use a pressure gauge to monitor pressure when making adjustments.

Spring Loaded Regulators and Relief Valves

1. Loosen locknut (Key 22)
2. Rotate the adjusting screw (Key 23) clockwise to increase the setting or counter clockwise to decrease the setting.
3. Tighten locknut.

Pressure Loaded Regulators and Relief Valves

1. Loosen the locknut found on the loading regulator adjusting screw.
2. Rotate the loading regulator adjusting screw clockwise to increase the setting or counterclockwise to decrease the setting.
3. Tighten locknut.

Taking out of Service

Isolate the regulator or relief valve from all pressure. For pressure loaded constructions, shut off supply pressure to loading regulator.

Cautiously vent all pressure from the regulator or relief valve before performing any service on the unit.

Maintenance

WARNING: To avoid personal injury and equipment damage, isolate the regulator or relief valve from all pressure. Cautiously release pressure from the regulator or relief valve before attempting disassembly.

Due to normal wear that may occur in regulators and relief valves, parts such as the valve disc, seat ring and diaphragm must be inspected periodically and replaced as necessary. The frequency of inspection and replacement depends upon the severity of service conditions or federal and provincial laws. Normal wear of the seat ring and valve disc is accelerated with high-pressure drops and with large amounts of impurities in the flow stream. Instructions are given below for replacing the seat ring, valve disc and diaphragm. These instructions may also be used for disassembly required for inspection and replacement of other parts.

If the loading regulator of pressure-loaded constructions requires maintenance, disconnect the supply pressure line (and bleed orifice vent line if one is present) and unscrew the loading regulator from its mounting nipple. Refer to the separate instruction manual for maintenance information.

Seat Ring and Valve Disc:

Note: With some piping systems it may be possible to omit step 1 below by removing four cap screws (Key 7) and spreading the body (Key 1) and adaptor (Key 6) far enough apart to allow removal of the seat ring (Key 4) and Type 630 HP valve disc (Key 3) or Type 630R valve seat O-ring (Key 32). However, take care to avoid pinching fingers between body and adapter.

1. Disconnect piping from Adapter (Key 6). Remove four cap screws (Key 7) and adapter.
2. Remove seat ring (Key 4) and gaskets (Key 5).
3. To remove Type 630 HP valve disc (Key 3) OR Type 630R valve seat O-ring (Key 32), first disconnect remote vent pipe (if one is used). For pressure loaded constructions, disconnect loading regulator supply line.
4. Unscrew the two cap screws that secure the diaphragm adaptor (Key 11) to body (Key 1); remove diaphragm adaptor and attach spring case (Key 21).
5. Remove valve carrier assembly (Key 2) from body.

6. To replace seating surface:
 - 6.1. For Type 630 HP, use a $\frac{3}{4}$ " socket wrench to remove and re-install valve disc and holder assembly (Key 3).
 - 6.2. For Type 630R, unscrew machine screw (key31) and remove O-ring washer and O-ring (Key 28 and 32) from O-ring holder (Key 3). When reassembling, apply a good quality gasket shellac to the machine screw thread.
7. Use new seat ring gaskets (Key 5) and body gasket (Key 8) when reassembling. Insert valve carrier assembly (Key 2) into the body before re-installing the diaphragm adaptor.
8. The spring case (Key 21) must point away from the adaptor (Key 6) on Type 630 HP regulators. On Type 630R relief valves, the spring case must face the same direction as the adaptor (Key 6). Be certain the lever (Key 10) engages the valve carrier.

Diaphragm

1. Relieve spring compression as follows:
 - 1.1 For spring loaded constructions, loosen locknut (Key 22). Turn the adjusting screw (Key 23) counterclockwise until spring compression is relieved.
 - 1.2 For pressure loaded Type 630R relief valves (and for pressure loaded Type 630 HP regulators that have been furnished with a spring), turn cap screw (Key 23) counterclockwise until spring compression is relieved.
2. Disconnect remote vent line (if one is present).
3. For pressure loaded constructions, disconnect the supply line from the loading regulator (Key 25).
4. Remove spring case (Key 21) by unscrewing cap screws and nuts (Key 14).
5. Remove diaphragm (Key 13) and attached parts from lever assembly (Key 10).
6. Unscrew cap screw (Key 18) from connector head assembly (Key 12) and disassemble the diaphragm assembly.
7. Install new diaphragm. Note that low-pressure constructions use a diaphragm plate (Key 16) on the spring case side of the diaphragm. Low pressure, pressure loaded constructions use a diaphragm plate on each side of the diaphragm plate gasket (Key 33) with each plate. Install new gaskets when replacing diaphragm.
8. When reassembling, be certain that the diaphragm connector is engaged on the lever.

9. To ensure proper slack in the diaphragm:
- 9.1 For constructions using a spring, tighten the spring case cap screws finger tight only. Compress the spring slightly with the adjusting screw (or cap screw for pressure loaded constructions); then complete the tightening of spring case cap screws and nuts.
- 9.2 For constructions without a spring, tighten spring case cap screws finger tight only. Remove cap screw (Key 23). Insert a rod in the spring case and push on the assembly to take up the slack; then complete the tightening of the spring case cap screws. Re-install cap screw (Key 23) in spring case.

Nameplate Information

When corresponding with your CVS Controls representative about this device, state the model number, pressure range and all other pertinent information found on the nameplate (Key 29). When ordering replacement parts, also specify the complete part number of each part required.

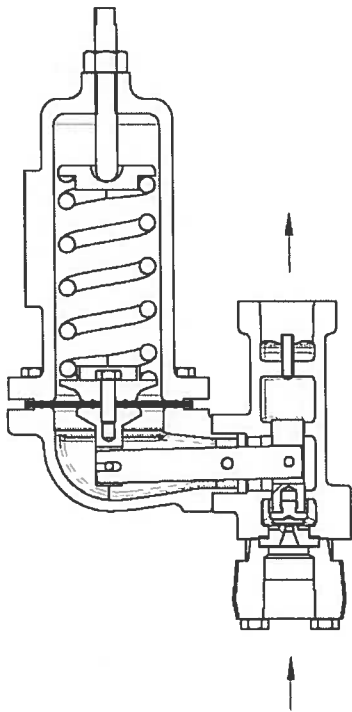

TYPE 630 REGULATOR OPERATIONAL SCHEMATIC

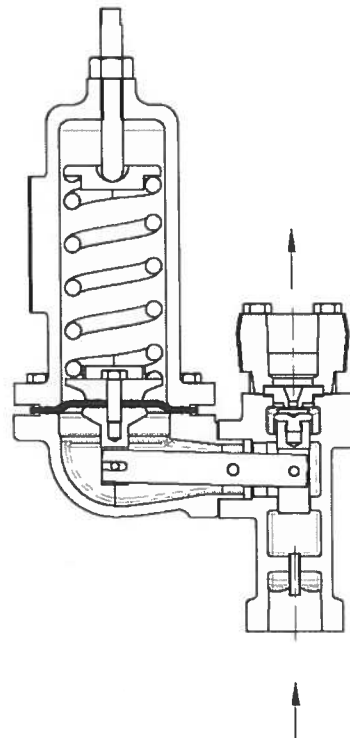

TYPE 630R RELIEF VALVE OPERATIONAL SCHEMATIC

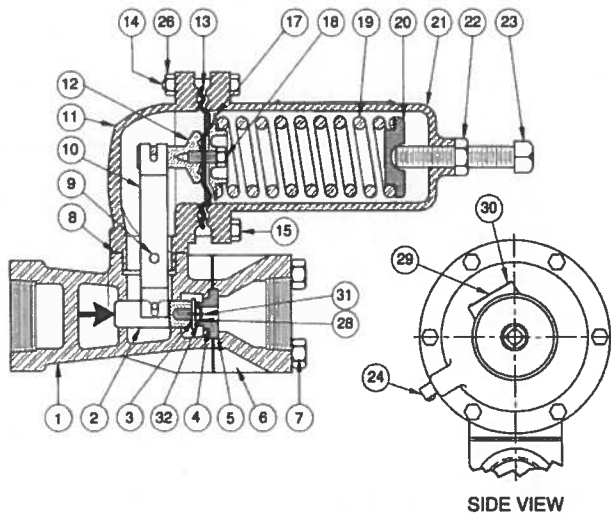

**Figure 1: Spring-Loaded CVS Type 630R
Relief Valve
High Pressure Connection**

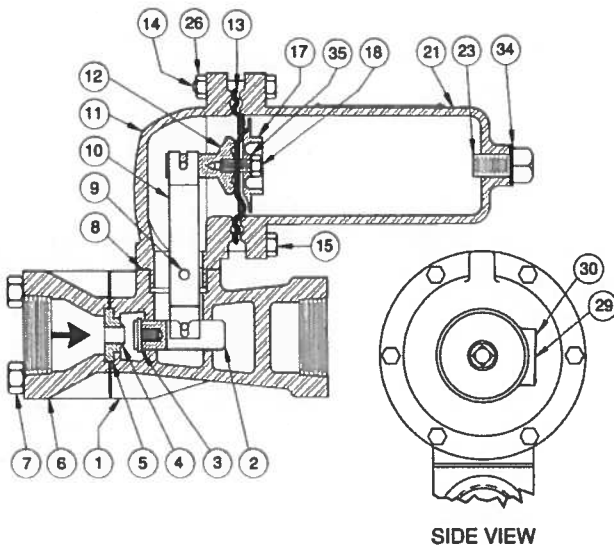

**Figure 2: Pressure-Loaded CVS Type 630
Regulator
High Pressure Connection**

Parts Reference

Key	Description
1	Body
2	Valve Carrier
3*	Type 630R O-Ring Holder Type 630* Valve Disc Assembly
4	Seat Ring
5	Gasket (2 required)
6	Inlet Adaptor, Steel
7	Cap Screw, Steel (4 required)
8*	Gasket
9	Pin, SST
10	Lever Assembly
11	Diaphragm Adaptor
12	Connector Head Assembly
13*	Diaphragm, Neoprene
14	Cap Screw, Steel
15	Cap Screw, Steel
16	Diaphragm Plate, Steel Cd. Pl.
17	Lower Spring Seat
18	Cap Screw, Steel Pl.
19	Spring
20	Upper Seat Ring, Zinc
21	Spring Case
22	Hex Nut, Steel Cd. Pl.
23	Adjusting Screw, Steel
24	Vent Assembly (Spring Loaded Only)
25	Loading (Pressure Loaded Only)
26	Hex Nut, Steel Cd. Pl.
27	Cap Screw, Steel Pl.
28	O-Ring Washer (Pressure Loaded Only)
29	Nameplate
30	Drive Screw, SST
31	Machine Screw (CVS Type 630R Only)
32	O-Ring
33	Head Gasket (Pressure Loaded Only)
34	Gasket (Pressure Loaded Only)
35	Gasket (Pressure Loaded Only)
36	Pipe Nipple (Pressure Loaded Only)
37	Street Elbow
38	Bleed Orifice Assembly (Pressure Loaded Only)

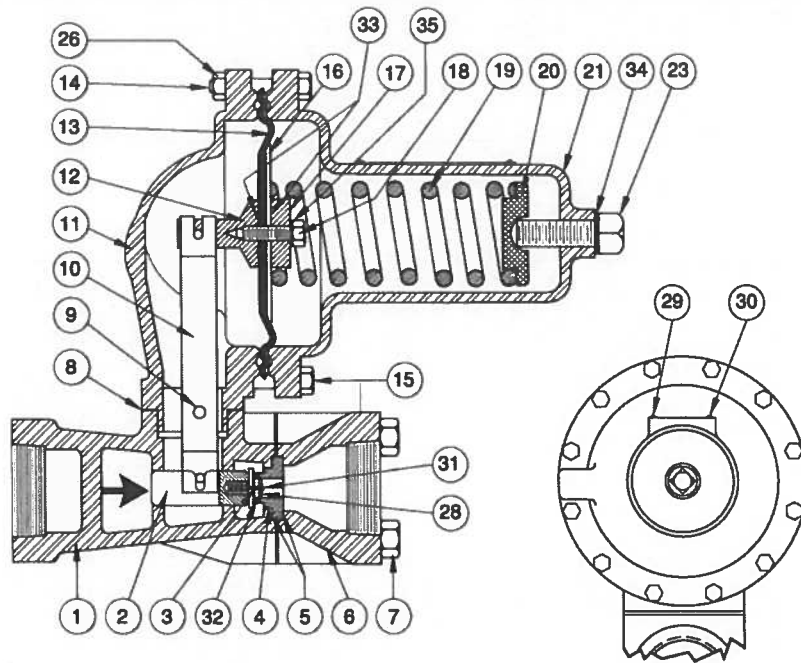

SIDE VIEW

**Figure 3: Spring-Loaded CVS Type 630R Relief Valve
Low Pressure Connection**

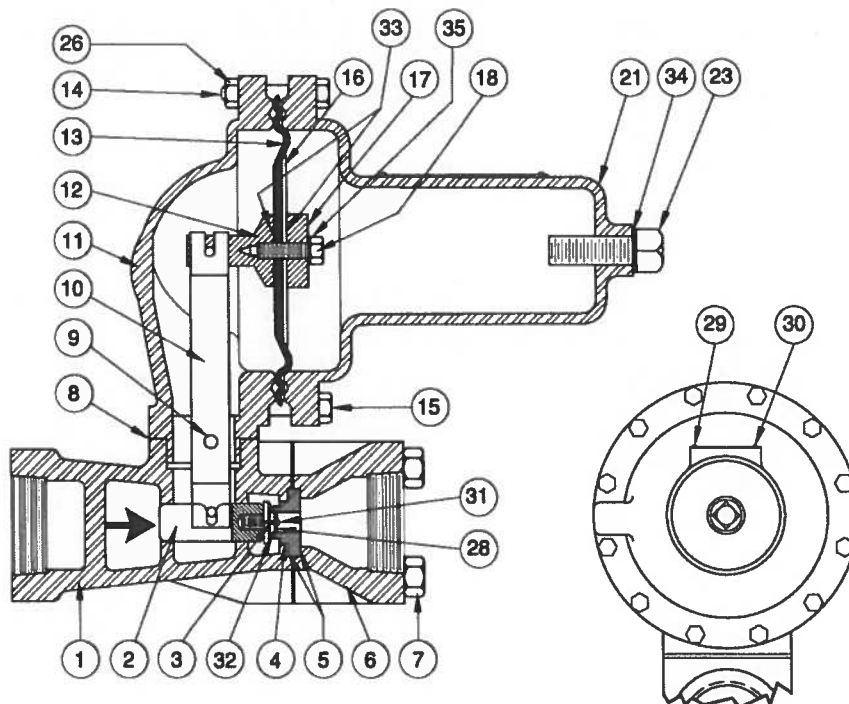

SIDE VIEW

**Figure 4: Pressure-Loaded CVS Type 630R Relief Valve
Low Pressure Connection**

CVS Type 630 HP Regulators and Relief Valves

Parts List

Key No.	Description		Part #	
1	Body			
		1" Steel w/ brass pitot tube	CVS2N6990000A2	
		1" Steel w/ SST pitot tube	CVS2N6990X0012	
2	Valve Carrier			
		2" Steel w/ SST pitot tube	CVS2N699122012	
3	O-Ring Holder, Type 630R	Brass	CVS0W018614022	
		SST	CVS0W018635032	
	Valve Disc Assembly, Type 630	Brass	CVS1D336014012	
		SST	CVS1D336035032	
		Brass/Nitrile	CVS1B4500000A2	
		SST/Nitrile	CVS1B4500000B2	
		Brass/Nylon	CVS1C1860000A2	
		SST/Nylon	CVS1C1860000B2	
Brass/TFE	CVS1C1860000C2			
SST/TFE	CVS1C1860000D2			
4	Seat Ring, Type 630	Brass	1/8" Port	CVS0Z040014012
			3/16" Port	CVS1B219514102
			1/4" Port	CVS0W018314012
			3/8" Port	CVS0W018214012
		SST	1/2" Port	CVS0W018114012
			1/8" Port	CVS1K416635032
			3/16" Port	CVS1K416535032
			1/4" Port	CVS1K416435032
	Seat Ring, Type 630R	Brass	3/8" Port	CVS1K416335032
			1/2" Port	CVS1K416235032
		SST	1/2" Port	CVS1B735014012
			1/2" Port	CVS1B735035032
5	Gasket (2 Req'd)	Copper, For Brass Trim	CVS0W018415042	
		Garlock	CVS0W018404022	
6	Inlet Adaptor, Steel	1-inch Body	CVS1F479823022	
		2-inch Body	CVS1F479923022	
7	Cap Screw, Steel (4 Req'd)	1-inch Body	CVS1A935924052	
		2-inch Body	CVS1A353524052	
8	Gasket, Non-Asbestos		CVS0W018704022	
9	Pin, SST		CVS0W018835072	
10	Lever Assembly	Low-Pressure	CVS1B2891000A2	
		High-Pressure	CVS1B2890000A2	
11	Diaphragm Adaptor	Low-Pressure	Steel	CVS2N698522012
			Steel	CVS2N698722012
		High-Pressure	Brass	CVS1C3000X0012
			SST	CVS1C3000X0022
12	Connector Head Assembly	Low-Pressure	Brass	CVS1P8465000A2
			SST	CVS1P8465000B2
		High-Pressure	Brass	CVS0W020002192
			SST	CVS0W019902192
13	Diaphragm, Neoprene	Low-Pressure	CVS1A352524052	
		High-Pressure	CVS1A352524052	
		Standard (2 Req'd)	CVS1A352624052	
14	Cap Screw, Steel	Low-Pressure (10 Req'd)	CVS1R419124052	
		High-Pressure (4 Req'd)	CVS1A352624052	
15	Cap Screw, Steel	Wire Seal (1 of Each Req'd)	CVS1A352624052	
			CVS1R419124052	
16	Diaphragm Plate, Steel Cd. Pl.	630 and 630R, Low-Pressure, Pressure-Loaded	CVS1A352524052	
		All Others	CVS0W020324102	
17	Lower Spring Seat	Low-Pressure, Steel	CVS0W020144022	
		High-Pressure, Zinc	Pressure Range to 275	CVS1K371044022
			Pressure Range over 275	
18	Cap Screw, Steel Pl.	630 and 630R, Low-Pressure, Pressure-Loaded	CVS1B136324052	
		All Others	CVS1R817699012	

**CVS Type 630 HP Regulators and Relief Valves
Parts List cont'd**

Key No.	Description	Part #
19	Spring	See Following Table
20	Upper Spring Seat, Zinc	630 Pressure Loaded None Required
		630 and 630R, and 630R Pressure-Loaded Pressure Range to 275 CVS0W019344022
21	Spring Case	Pressure Range over 275 CVS1K371144022
		Low Pressure Cast Iron CVS3C780919042
21	Spring Case	Steel CVS3N698122012
		High Pressure Cast Iron CVS3C780819042
21	Spring Case	Steel CVS3N698322012
22	Hex Nut, Steel Cd. Pl.	CVS1A352424122
23	Adjusting Screw, Steel	See Following Table
24	Vent Assembly (Not Required for Pressure-Loaded Units)	CVSEMY602X1A12
25	Loading Regulator (For Pressure-Loaded Only)	Type 67, 67H, 1301F or 1301G
26	Hex Nut, Steel Cd. Pl.	Low-Pressure (10 Req'd) CVS1A352724122
		High-Pressure (4 Req'd) CVS1A352724122
27	Cap Screw, Steel Pl. (2 Req'd) (Not Shown)	CVS1A341827052
28	O-Ring Washer (For Pressure-Loaded Units Only)	Brass CVS1D335914012
		SST CVS1D335935072
29	Nameplate, Aluminum	Type 630 CVS1F749611032
		Type 630R CVS21A5495X012
30	Drive Screw, SST (4 Req'd)	CVS1A368228982
31	Machine Screw, Type 630R Only	Brass CVS1A682618992
		SST CVS1D336435042
32	O-Ring	Nitrile CVS1D288806992
		TFE CVS1F581906522
33	Head Gasket, Garlock (2 Req'd), (For Pressure-Loaded Units Only)	CVS1B192204022
34	Gasket, Copper (For Pressure-Loaded Units Only)	CVS0Y008915042
35	Gasket, Copper and Garlock (For Pressure-Loaded Units Only)	CVS1E275999212
36	Pipe Nipple, Steel Galvanize Zn Pl (Pressure-Loaded Units Only)	CVS1B218826232
37	Street Elbow, Malleable Iron (High-Pressure, Pressure-Loaded Units)	CVS1A913221992
38	Bleed Orifice Assembly (Pressure-Loaded Only)	Low Pressure 3-20 psig Loading Regulator Range CVS1K8845X0012
		20-100 psig Loading Regulator Range CVS1K8844X0012
		High-Pressure CVS1K8843X0012

Key 23: Adjusting Screw, Steel

Type	Spring	Use Adjusting Screw	For Wire Seal, Use Adjusting Screw
CVS 630	CVS0W019227022	CVS1A279128982	CVS1R829928992
	CVS0W019127022	CVS1B212028982	CVS1R830028992
	CVS0W019027022	CVS1A500528982	CVS1R808528992
	CVS0Y0664000A2	CVS1A500528982	CVS1R808528992
	CVS1J146927142	CVS1A500528982	CVS1R808528992
	CVS1K370927082	CVS1A500528982	CVS1R808528992
	None *	CVS1C116227092	---
CVS 630R	CVS0W019227022	CVS1A279128982	CVS1R829928992
	CVS0W019127022	CVS1B212028982	CVS1R830028992
	CVS0W019027022	CVS1A500528982	CVS1R808528992
	CVS0Y0664000A2	CVS1D336628982	CVS1R830128992
	CVS1J146927142	CVS1D336628982	CVS1R830128992
	CVS0W019227022*	CVS1E359024492	---

* Pressure-Loaded Construction

Key 19: Regulator Spring, Steel

Type		Outlet (or Relief) Pressure Setting, PSIG	Spring Part Number	Spring Colour Code
Spring-Loaded Type 630	Low-Pressure	3 to 10	CVS0W019227022	Red Stripe
		8 to 20	CVS0W019127022	Olive Drab
		17 to 30	CVS0W019027022	Cadmium
		27 to 40	CVS0Y0664000A2	Green Stripe
	High-Pressure	27 to 50	CVS0W019227022	Red Stripe
		46 to 95	CVS0W019127022	Olive Drab
		90 to 150	CVS0W019027022	Cadmium
		150 to 200	CVS0Y0664000A2	Green Stripe
200 to 275		CVS1J1469270142	Blue Stripe	
275-500	CVS1K370927082	Yellow Stripe		
Spring-Loaded Type 630R	Low-Pressure	3 to 8	CVS0W019227022	Red Stripe
		6 to 17	CVS0W019127022	Olive Stripe
		15 to 22	CVS0W019027022	Cadmium
		20 to 35	CVS0Y0664000A2	Green Stripe
	High-Pressure	27 to 50	CVS1J146927142	Blue Stripe
		30 to 70	CVS0W019127022	Olive Drab
		50 to 95	CVS0W019027022	Cadmium
		75 to 175	CVS0Y0664000A2	Green Stripe
150 to 250	CVS1J146927142	Blue Stripe		
Pressure-Loaded Type 630 R	Low-Pressure	10 to 20 or 20 to 50	CVS0W019227022	Red Stripe
	High-Pressure	50 to 100 or 100 to 225	CVS0W019227022	Red Stripe

Dimensional Data:

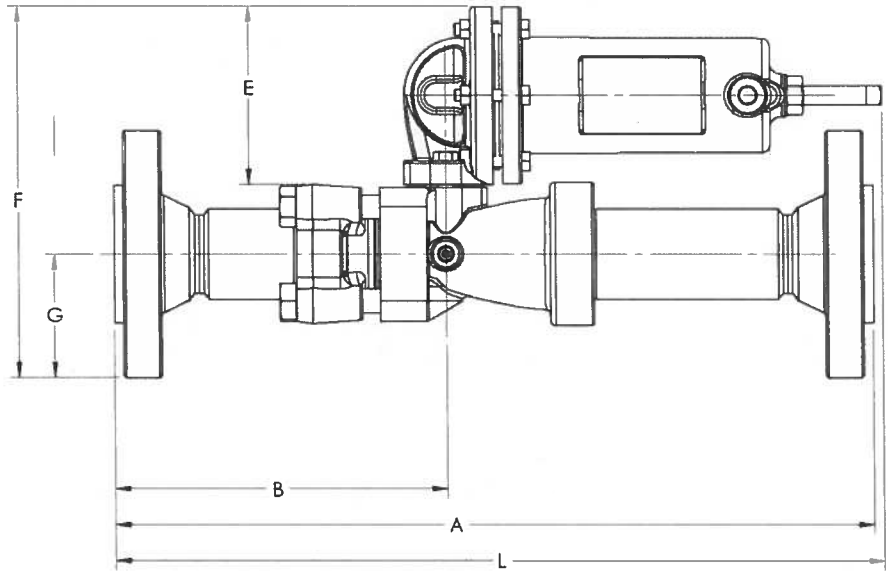

BODY SIZE		FLANGED DIMENSIONS															
		A		B		E		F				G				L	
								CL150		CL300 & CL600		CL150		CL300 & CL600			
LOW-PRESSURE REGULATOR																	
INCH	DN	INCHES	MM	INCHES	MM	INCHES	MM	INCHES	MM	INCHES	MM	INCHES	MM	INCHES	MM	INCHES	MM
1	25	17.9	455	8	203	7.2	183	11.1	282	11.4	290	2.1	53.3	2.4	61.0	20.7	526
2	50	19.9	505	9	229	7.2	183	11.9	302	12.2	310	3.0	76.2	3.3	83.8	21.9	556
HIGH-PRESSURE REGULATOR																	
1	25	17.9	455	8	203	4.7	119	8.6	218	8.9	226	2.1	53.3	2.4	61.0	21.2	538
2	50	19.9	505	11.2	284	4.7	119	9.4	239	9.7	246	3.0	76.2	3.3	83.8	21.4	544

CVS Type 630 Regulator – Capacity Data

Table 1 contains flow capacities in Standard Cubic Feet per Hour of 0.6 specific gravity gas. Alternate flow rates for other gasses may be determined by multiplying the table value by the appropriate factor: Air – 0.775; Nitrogen – 0.789; Propane – 0.628; Butane; 0.548.

Table 1: CVS Type 630 Regulator Capacity – SCFH of 0.6 Specific Gravity Gas; based on 20% Droop

	OUTLET PRESSURE RANGE	INLET PRESSURE PSIG	OUTLET PRESSURE PSIG	1 Inch Body Port Diameter - Inches					2 Inch Body Port Diameter - Inches				
				1/8	3/16	1/4	3/8	1/2	1/8	3/16	1/4	3/8	1/2
		10		200	510	990	1700	2200	290	830	1300	3300	5900
		20		400	770	1200	2000	2700	500	1200	2100	5600	9100
		30		600	1100	1500	2200	3300	760	1600	2700	7000	11000
		50		950	1500	2100	2800	4200	1100	2200	3900	9800	17000
		60		1100	1750	2400	3000	4100	1250	2700	4500	11100	19500
	3 to 10 PSIG	75		1300	2100	2700	3400	4400	1500	3300	5400	13000	23000
	Spring: CVS	100		1700	2400	2900	4000	4900	1900	4300	7000	17000	30000
	OW019227022	150	5	2200	3000	3500	4600	5800	2800	6200	10000	25000	43000
	Red Stripe	200		3000	3400	4200	5100	6100	3700	8200	13000	32000	57000
		250		3500	3800	4300	5900	6800	4500	10000	17000	38000	70000
		400		3700	3900	4500	6400		7200	16000	28000	64000	
		500		4100	4300	4700	7400		9100	19000	35800	79000	
		600		4300	4600	5000			10000	24000	42000		
		1000		4600	4900	5600			18000	39000	69000		
		1500		5000	5400				22000	60000			
L O W		20		500	1200	1800	4200	4900	560	1300	2200	5100	9000
		30		700	1400	2800	4100	5300	770	1500	3000	7000	11000
		50		1000	2300	4100	5100	6200	1100	2400	4300	9800	17000
		60		1150	2700	4200	5500	6500	1250	2800	5000	11100	19500
		75		1400	3200	4400	6000	6800	1500	3400	5900	13000	23000
P R E S U R E	3 to 10 PSIG	100		1600	3800	5000	6400	7300	1900	4400	7600	17000	30000
	Spring: CVS	150		2400	4800	6200	7300	7900	2800	6200	11000	25000	43000
	OW019227022	200	10	3300	5800	6900	7700	8200	3700	8100	14000	33000	57000
	Red Stripe	250		4000	5900	7300	8600	8700	4400	10000	17000	41000	70000
		400		5400	6900	7600	9000		7200	16000	28000	62000	
	500		6000	7100	7900	9700		8900	19000	35000	76000		
	600		6500	7300	8200			10000	23000	42000			
	1000		7200	7700	8400			18000	40000	72000			
	1500		7400	8400				27000	60000				
		20		500	700	1400	2200	3600	550	1200	1700	2500	4900
		30		700	1300	2100	3100	4300	760	1500	2500	4600	8800
		50		900	1900	3200	4300	5400	1000	2300	3800	7800	16000
		60		1050	2300	3500	4700	5800	1200	2700	4500	9900	18500
		75		1300	2800	4000	5200	6400	1500	3300	5600	12000	23000
	8 to 20 PSIG	100		1600	3500	4600	5700	6900	1900	4300	7400	17000	30000
	Spring: CVS	150		2400	4400	5700	6800	7800	2800	6100	11000	25000	44000
	OW019127022	200	10	3300	4800	6200	7500	8200	3600	8000	14000	32000	57000
	Olive Drab	250		4000	5800	7000	8000	8700	4400	9500	17000	37000	70000
		400		5400	6500	7600	8900		7200	15000	28000	60000	
		500		6000	6900	7900	8900		8800	19000	35000	74000	
		600		6500	7000	8200	9400		10000	23000	42000		
		1000		7200	7700	8400			18000	39000	72000		
		1500		7400	8100				27000	60000			

Table 1(continued): CVS Type 630 Regulator Capacity – SCFH of 0.6 Specific Gravity Gas; based on 20% Droop

	Outlet Pressure Range	Inlet Pressure PSIG	Outlet Pressure PSIG	1 Inch Body Port Diameter - Inches					2 Inch Body Port Diameter - Inches				
				1/8	3/16	1/4	3/8	1/2	1/8	3/16	1/4	3/8	1/2
		20		470	1000	1700	3300	4900	520	1100	1800	3500	5700
		30		600	1500	2500	4600	5200	740	1600	2800	5900	10000
		50		1000	2300	3800	5500	5700	1100	2400	4300	9800	16000
		60		1150	2700	4300	6100	6800	1250	2800	5000	11100	18500
		75		1400	3300	5100	7000	8500	1500	3400	6000	13000	23000
	8 - 20 PSIG	100		1800	4100	6200	7600	9600	2300	4400	7800	17000	30000
	Spring: CVS	150		2700	6100	7400	8000	9900	2800	6400	11000	25000	43000
	OW019127022	200	15	3600	7500	8500	9600	10000	3700	8300	14000	30000	57000
	Olive Drab	165		4700	8400	9100	10000	11000	4800	10000	19000	39000	74000
		400		7100	8700	10000	11000		7200	16000	29000	64000	
		515		8300	8800	10500	12000		9200	20000	37000	82000	
		600		8600	9600	10800			11000	23000	42000		
		1015		9600	10000	11000			18000	40000	71000		
		1500		10000	11000				27000	60000			
		30		600	1500	2500	4600	6800	700	1600	2600	5200	9200
		40		800	2000	3400	5700	8100	900	2100	3500	7500	12000
		50		1000	2300	4200	6800	9000	1100	2400	4300	9400	15000
		60		1150	2700	4900	7500	9800	1250	2800	5100	11000	18000
		75		1400	3300	5900	8500	10000	1500	3400	6100	13000	23000
	8 - 20 PSIG	100		1800	4100	7400	9500	11000	1900	4300	7800	17000	29000
	Spring: CVS	150		2700	6100	9200	11000	12000	2800	6300	11000	23000	42000
	OW019127022	200	20	3600	8000	10000	12000	13000	3700	8200	14000	32000	59000
	Olive Drab	270		4500	9800	11000	13000	14000	4900	10000	19000	39000	75000
		400		7200	10000	13000	14000		7300	16000	28000	63000	
		520		8800	11000	13500	15000		9500	20000	37000	82000	
		600		10000	12000	13800			11000	24000	43000		
		1020		11000	12300	15000			18000	40000	73000		
		1500		12000	13000				27000	60000			
		30		590	900	1700	3300	4700	680	1300	2100	3500	6000
		40		790	1700	2400	4000	6100	890	1800	2800	5100	8200
		50		900	2200	3600	4900	6900	1000	2300	3700	6200	10000
		60		1050	2500	4000	5500	7400	1200	2700	4300	7400	12500
		75		1300	3000	4500	6400	8100	1500	3300	5300	9200	16000
	17 - 30 PSIG	100		1700	4000	5500	7600	9700	1900	4200	5900	12000	24000
	Spring: CVS	150		2100	5500	7000	9600	11000	2200	6100	10000	21000	40000
	OW019027022	200	20	3400	6400	9100	11000	12000	3500	8000	13000	32000	56000
	Cadmium	270		4400	8400	10000	12000	13000	4800	10000	19000	39000	75000
		400		7000	9700	11000	13000		7100	15000	28000	63000	
		520		8200	10000	12000	13800		9300	20000	37000	82000	
		600		9600	11000	13000			10000	23000	42000		
		1020		10000	12000	14000			18000	40000	72000		
		1500		12000	13000				27000	60000			
		40		820	1700	2700	5100	7600	860	1800	2900	5300	8500
		50		900	2200	3600	6400	8700	1000	2300	3800	7300	11000
		60		1100	2600	4400	7500	9800	1200	2700	4700	8900	14000
		75		1400	3300	5400	8800	11000	1500	3400	5800	11000	18000
		100		1700	4100	6800	10000	12000	1800	4200	9800	16000	28000
	17 - 30 PSIG	150		2600	6000	9100	13000	14000	2700	6100	11000	20000	44000
	Spring: CVS	200		3500	8000	11000	14000	16000	3600	8100	14000	24000	58000
	OW019027022	280	30	4900	10500	13000	15000	17000	5000	11000	20000	46000	80000
	Cadmium	400		6900	13000	15000	17000		7000	16000	28000	64000	
		530		9400	14500	15800	19000		9500	20000	37000	86000	
		600		9700	15000	16000			10000	23000	42000		
		1030		16000	18000	18000			19000	41000	73000		
		1500		16400	18500				27000	61000			

Continued,

Table 1(continued): CVS Type 630 Regulator Capacity – SCFH of 0.6 Specific Gravity Gas; based on 20% Droop

	OUTLET PRESSURE RANGE	INLET PRESSURE PSIG	OUTLET PRESSURE PSIG	1 Inch Body					2 Inch Body				
				Port Diameter - Inches					Port Diameter - Inches				
				1/8	3/16	1/4	3/8	1/2	1/8	3/16	1/4	3/8	1/2
		40		800	1500	2400	4400	6400	850	1600	2600	4500	7200
		50		900	2000	3200	5600	7700	1000	2200	3500	5900	9700
		60		1100	2500	3900	6300	8900	1200	2600	4200	7300	12000
L		75		1400	3000	4700	7700	10000	1500	3200	5300	9400	15000
O		100		1700	3900	6400	9400	11000	1800	4200	6900	12000	23000
W	27 to 40 PSIG	150		2600	5700	8800	12000	14000	2700	6100	10000	20000	39000
	Spring: CVS	200		3500	7000	9400	14000	15000	3600	8100	13000	24000	57000
P	OY0664000A2	280	30	4900	10000	13000	15000	16000	5000	11000	19000	45000	78000
R	Green Stripe	400		6900	12000	15000	17000		7000	15000	28000	64000	
E		530		9400	12600	15800	18000		9500	20000	37000	85000	
S		600		9700	13400	16000			10000	23000	42000		
S		1030		16000	16000	18000			19000	41000	73000		
U		1500		16400	18000				27000	61000			
R		50		950	1800	3200	5500	8900	1000	2100	3400	5900	9900
E		60		1100	2300	4100	7600	10000	1200	2600	4300	7900	12000
		75		1400	3000	5300	9300	12000	1500	3600	5600	10000	16000
		100		1800	4100	7000	11000	14000	1900	4300	7200	13000	24000
	27 to 40 PSIG	150		2700	6000	9500	14000	17000	2800	6200	10000	22000	39000
	Spring: CVS	200		3500	7800	12000	17000	19000	3600	8200	14000	30000	56000
	OY0664000A2	290	40	5100	10000	15000	19000	21000	5200	11000	20000	46000	81000
	Green Stripe	400		7100	15000	18000	21000		7200	16000	28000	63000	
		540		9500	17000	19000	22000		9600	21000	38000	86000	
		600		9800	18000	21000			10000	23000	42000		
		1040		17500	20000	23000			18000	41000	73000		
		1500		20000	22000				27000	61000			
		60		900	2000	3100	5200	8100	1000	2100	3200	5300	12000
		75		1300	2800	3800	7200	10000	1400	2900	3900	7300	16000
		100		1700	3500	5700	10500	13000	1800	3600	5800	10000	21000
	27 to 50 PSIG	150		2600	5700	8700	13000	17000	2700	5800	9000	15000	36000
	Spring: CVS	200		3500	7800	11000	16000	19000	3600	7900	12000	21000	55000
H	OW019227022	300	50	5300	10500	14000	20000	23000	5500	11000	19000	48000	83000
I	Red Stripe	400		6900	13000	17000	23000		7000	15000	27000	63000	
G		550		9600	16000	20000	26000		9700	21000	38000	88000	
H		600		9800	17000	21000			10000	23000	42000		
		1050		17000	23000	27000			19000	42000	74000		
P		1500		19000	25000				27000	60000			
R		60		800	1500	2400	4300	6400	900	1600	2500	4400	7300
E		75		1200	2100	3100	5500	8000	1300	2200	3200	6100	9300
S		100		1500	3100	4200	7500	10000	1600	3400	4300	7600	12000
S	46 to 95 PSIG	150		2400	4500	6700	11000	14000	2500	4600	7100	12000	19000
U	Spring: CVS	200		3400	6600	9400	14000	17000	3500	6700	9600	16000	27000
R	OW019127022	300	50	5200	8900	11000	16000	20000	5300	10000	14000	27000	51000
E	Olive Drab	400		6800	11000	15000	20000		6900	13000	21000	46000	
		550		9500	13000	17000	23000		9600	18000	29000	87000	
		600		9800	14000	19000			10000	20000	35000		
		1050		14000	19000	22000			18000	41000	73000		
		1500		18000	24000				26000	59000			
		100		1700	3200	5000	8000	13000	1800	3300	5200	9000	14000
		125		2200	4300	6700	10000	15000	2300	4400	6900	11000	18000
		200		3500	7300	10000	16000	22000	3600	7400	11000	19000	30000
	46 to 95 PSIG	250		4400	9400	13000	19000	24000	4500	9500	14000	26000	44000
	Spring: CVS	325	75	5700	11000	16000	23000	27000	5800	12000	18000	36000	67000
	OW019127022	400		7100	14000	19000	27000		7200	15000	24000	47000	
	Olive Drab	575		9700	18000	23000	30000		9800	22000	37000	92000	
		600		9900	19000	25000			10000	23000	39000		
		1075		18000	27000	32000			19000	42000	75000		
		1500		23000	32000				24000	60000			

Continued,

Table 1(continued): CVS Type 630 Regulator Capacity – SCFH of 0.6 Specific Gravity Gas; based on 20% Droop

	OUTLET PRESSURE RANGE	INLET PRESSURE PSIG	OUTLET PRESSURE PSIG	1 Inch Body Port Diameter - Inches					2 Inch Body Port Diameter - Inches				
				1/8	3/16	1/4	3/8	1/2	1/8	3/16	1/4	3/8	1/2
H I G H P R E S S U R E	90 to 150 PSIG Spring: CVS OW019027022 Cadmium	125	100	2000	3600	5500	9200	13000	2100	3700	5600	9800	15000
		150		2500	4600	6800	11000	16000	2600	4900	7400	12000	18000
		200		3600	6600	9400	13000	22000	3700	5900	10000	17000	27000
		250		4400	8500	11000	18000	26000	4500	8700	13000	22000	34000
		300		5300	9800	14000	21000	30000	5400	10000	16000	27000	44000
		350		6100	10000	16000	25000	32000	6300	12000	19000	33000	57000
		400		7000	13000	18000	27000		7200	14000	21000	39000	
		600		9500	18000	23000	35000		10000	21000	34000	69000	
	1100	19500	28000	35000			19000	43000	74000				
	1500	25000	35000				27000	59000					
	90 to 150 PSIG Spring: CVS OW019027022 Cadmium	150	125	2400	4600	6700	11000	17000	2500	5000	8100	12000	20000
		200		3500	6800	10000	15000	23000	3600	7400	11000	19000	30000
		250		4300	8900	12000	19000	29000	4400	9400	14000	24000	39000
		300		5200	10000	15000	25000	34000	5300	11000	17000	31000	48000
		375		6600	13000	18500	28000	39000	7000	15000	24000	43000	45000
400		7300		14500	19000	29000		8300	18000	28000	56000		
500		7900		15000	25000	36000		8800	19000	30000	59000		
625		10000		22000	29000	41000		11000	24000	40000	79000		
1125	18000	33000	42000			19000	44000	79000					
1500	26000	43000				27000	60000						
90 to 150 PSIG Spring: CVS OW019027022 Cadmium	200	150	3400	6800	10000	16000	26000	3500	7300	11000	18000	30000	
	250		4400	8800	13000	20000	32000	4500	9500	15000	26000	38000	
	300		5300	10000	15000	24000	35000	5400	11000	19000	32000	52000	
	400		7100	14000	22000	34000	42000	7200	15000	26000	46000	77000	
	450		7700	17000	24000	36000		8100	18000	29000	54000		
	650		9000	24000	33000	49000		10000	25000	44000	88000		
	800		13000	29000	38000			14000	30000	54000			
	1150		20000	38000	49000			21000	46000	78000			
1500	26000	47000				27000	60000						
150 to 200 PSIG Spring: CVS OY0664000A2 Green Stripe	200	150	3400	6200	9300	16000	24000	3500	6900	10000	17000	28000	
	250		4300	8800	12000	20000	27000	4400	9000	13000	23000	36000	
	300		5300	10000	15000	24000	30000	5400	11000	17000	28000	47000	
	400		7100	14000	21000	32000	38000	7200	15000	24000	40000	66000	
	450		7600	15000	24000	36000		8000	17000	27000	46000		
	650		9000	21000	33000	48000		10000	22000	40000	74000		
	800		13000	27000	37000			14000	30000	51000			
	1150		19500	34000	49000			20000	45000	78000			
1500	26000	44000				27000	60000						
150 to 200 PSIG Spring: CVS OY0664000A2 Green Stripe	250	200	4200	8300	12000	20000	30000	4300	9100	13000	23000	42000	
	300		5200	10000	16000	25000	35000	5300	11000	18000	33000	52000	
	450		7800	16000	26000	43000	50000	7900	17000	29000	52000	84000	
	600		9500	22000	34000	55000		10000	23000	40000	75000		
	700		11000	25000	40000	61000		12000	27000	47000	90000		
	800		13000	30000	43000			14000	31000	54000			
	1000		16000	37000	50000			17000	39000	69000			
	1200		20000	41000	59000			21000	48000	83000			
1500	26000	53000				27000	60000						
200 to 275 PSIG Spring: CVS 1J146927142 Blue Stripe	250	200	4200	8200	11000	20000	29000	4300	8900	12000	23000	35000	
	300		5200	10000	14500	25000	35000	5300	11000	18000	31000	46000	
	450		7700	16000	24000	40000	50000	7800	17000	28000	50000	78000	
	600		9500	22000	31000	51000		10000	23000	38000	70000		
	700		11000	25000	35000	55000		12000	27000	45000	83000		
	800		13000	29000	42000			14000	31000	52000			
	1000		16000	36000	50000			17000	39000	68000			
	1200		19000	41000	55000			20000	46000	83000			
1500	26000	51000				27000	60000						

Continued,

Table 1(continued): CVS Type 630 Regulator Capacity – SCFH of 0.6 Specific Gravity Gas; based on 20% Droop

	OUTLET PRESSURE RANGE	INLET PRESSURE PSIG	OUTLET PRESSURE PSIG	1 Inch Body					2 Inch Body				
				Port Diameter - Inches					Port Diameter - Inches				
				1/8	3/16	1/4	3/8	1/2	1/8	3/16	1/4	3/8	1/2
H I G H P R E S S U R E S U E	200 to 275 PSIG Spring: CVS 1J146927142 Blue Stripe	300	250	4900	9000	15000	28000	42000	5000	10000	17000	30000	5200
		400		7000	14000	23000	40000	56000	7100	15000	25000	47000	76000
		500		8500	18000	29000	51000	65000	8600	19000	34000	62000	103000
		600		9500	22000	34000	59000		10000	23000	41000	78000	
		750		12500	28000	44000	69000		13000	29000	51000	106000	
		1000	16000	39000	58000			17000	40000	68000			
		1250	21000	49000	69000			22000	50000	87000			
		1500	26000	59000				27000	60000				
		300	275	4700	9000	15000	28000	39000	4800	10000	17000	29000	43000
	200 to 275 PSIG	400		6900	14000	25000	40000	54000	7000	15000	26000	47000	73000
Spring: CVS	525	8600		18000	35000	68000	94000	9200	20000	36000	69000	112000	
1J146927142	775	11000		28000	51000	95000		12000	30000	52000	112000		
Blue Stripe	1000	16000		39000	67000			17000	40000	68000			
	1275	21000	50000	87000			22000	51000	89000				
	1500	26000	60000				26000	61000					
S U R E S U E	275 to 500 PSIG Spring: CVS 1K370927082 Yellow Stripe	300	275	4500	7500	10000	20000	31000	4600	8400	13000	23000	37000
		400		6600	12000	16000	31000	43000	7000	13000	20000	32000	53000
		525		8600	16000	21000	39000	56000	9300	18000	27000	46000	73000
		775		11000	24000	32000	55000		13000	28000	44000	73000	
		1000		17000	32000	43000			18000	37000	57000		
		1275	21000	40000	53000			22000	48000	77000			
		1500	26000	46000				27000	57000				
	275 to 500 PSIG Spring: CVS 1K370927082 Yellow Stripe	400	300	6600	11000	16000	31000	42000	7000	13000	21000	35000	54000
		550		9700	18000	23000	44000	63000	9800	20000	30000	52000	78000
		600		9900	19000	26000	48000		10000	21000	34000	59000	
700		11000		23000	30000	54000		12000	26000	40000	72000		
800		13000		26000	35000	61000		14000	29000	47000	81000		
	900	15000	29000	39000			16000	34000	53000				
	1300	22000	43000	58000			23000	50000	80000				
	1500	26000	49000				27000	58000					
275 to 500 PSIG Spring: CVS 1K370927082 Yellow Stripe	500	400	8300	16000	24000	44000	62000	8800	17000	28000	49000	77000	
	650		10000	24000	33000	61000	86000	11000	25000	40000	75000	112000	
	800		13000	30000	41000	76000		14000	31000	51000	95000		
	900		15000	34000	49000	85000		16000	36000	58000	110000		
	1000		17000	38000	54000			18000	40000	66000			
	1200		20000	46000	63000			21000	48000	80000			
	1400		24000	55000	76000			25000	57000	96000			
1500	26000	60000				27000	61000						
275 to 500 PSIG Spring: CVS 1K370927082 Yellow Stripe	550	500	8700	16000	26000	50000	77000	9000	18000	30000	53000	89000	
	750		12000	28000	40000	78000	100000	13000	29000	48000	90000	141000	
	900		15000	34000	52000	92000		16000	35000	60000	113000		
	1000		17000	39000	60000	100000		18000	40000	67000	130000		
	1500		26000	59000	72000			27000	60000	82000			

CVS Controls Ltd. strives for the highest levels of quality and accuracy. The information included in this publication is presented for informational purposes only. CVS Controls Ltd. reserves the right to modify or change, and improve design, process, and specifications without written notice. Under no circumstance is the information contained to be interpreted to be a guarantee/warranty with regard to our products or services, applicability or use. Selection, use and maintenance are the sole responsibility of the end user and purchaser. CVS Controls assumes no liability for the selection use and maintenance of any product.